

NOCCHI JET

CAST IRON SELF-PRIMING PUMPS

STURDY, SELF-PRIMING, LARGE INTAKE CAPACITY

The self-priming pumps in the JET range combine the advantages and practical features of centrifugal pumps with the functionality of self-priming pumps. The Venturi pipe system on these pumps guarantees optimal hydraulic performance and impressive suction capacity, maintaining priming even in the presence of air or gas bubbles trapped in the water.

MOTOR

- Closed, ventilated from exterior.
- Protection rating IP 44.
- Insulation class F.
- Single phase power supply with permanently activated capacitor and thermal cutout protection incorporated in the motor winding.
- Three phase power supply with external protection to be fitted by the user.
- Rotation speed 2850 rpm.
- Continuous duty.

APPLICATIONS

- Lifting and distribution of water in domestic systems in continuous or intermittent operation.
- Pressurization systems.
- Washing, garden irrigation, supply to fountains, transfers.
- Lifting from wells or tanks.

USAGE DATA

- Type of liquid: clean water without suspended solid bodies or abrasive material.
- Maximum temperature of the liquid 50°C.
- Maximum recommended suction height 8 m with foot valve.
- Maximum operating pressure: 6 bar. (10 bar for mod. 100 - 160)

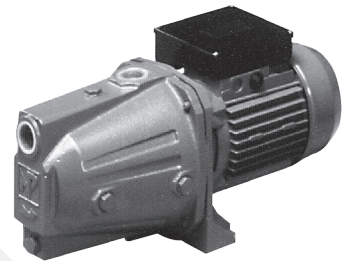
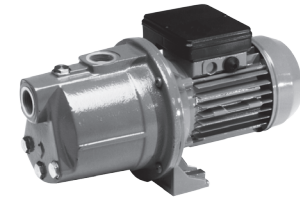

TABLE OF MATERIALS

Component	Material	
	NEW JET	JET
1 Pump body	Cast iron EN GJL 200	Cast iron EN GJL 200
2 Motor casing	Aluminium	Cast iron EN GJL 200
3 Impellers	Technopolymer with stainless steel shim ring X5 CrNi 1810 (AISI 304)	Technopolymer models 600-800-1000
		Moulded brass alloy models 100-160-800-1000
4 Diffuser-Venturi tube-nozzle	Monobloc group Technopolymer	Technopolymer
5 Motor shaft	Stainless steel X 12 CrNiS 1809 (AISI 416)	Stainless steel X 12 CrNiS 1809(AISI 416)
6 Mechanical seal	Graphite	Graphite
7 Counterface	Ceramic	Ceramic
8 Gaskets	NBR 70 shore	NBR 70 shore

NOCCHI JET

CAST IRON SELF-PRIMING PUMPS

HYDRAULIC PERFORMANCE

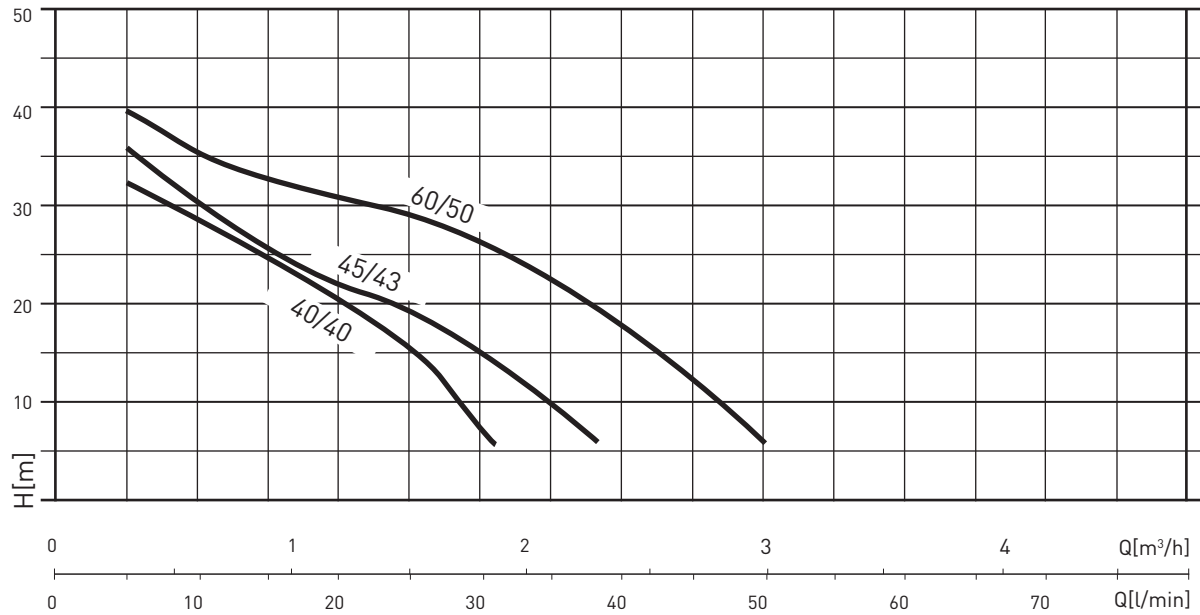

PERFORMANCE TABLE

MODEL	Motor power (P2)		Motor power (P1)		VOLT. (V)	I _n (A)	μF	Q	Q					
	HP	kW	HP	kW					l/min	0	10	20	30	40
									0	0.6	1.2	1.8	2.4	3
NEWJET 40/40 M	0.5	0.37	0.8	0.6	1 ~ 230	3	6	m.c.a./m.c.w.	41	28	21	8		
NEWJET 45/43 M	0.5	0.37	0.8	0.6	1 ~ 230	3	8		43	30	23	16	1	
NEWJET 60/50 M	0.75	0.35	1.1	0.8	1 ~ 230	4	12.5		43	36	31	26	18	6

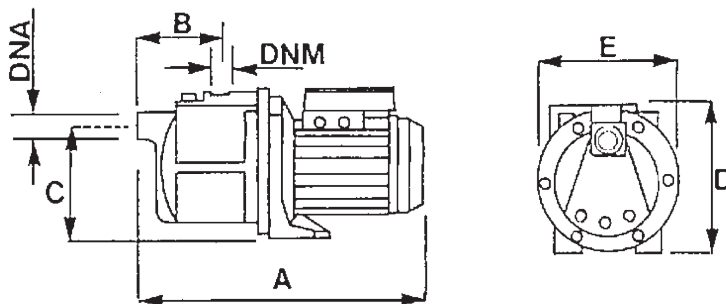

OVERALL DIMENSIONS AND WEIGHTS

MODEL	Dimensions mm.							WEIGHTS (Kg)
	A	B	C	D	E	DNA	DNM	
NEWJET 40/40	351	93	130	180	174	1"	1"	8.2
NEWJET 45/43	351	93	130	180	174	1"	1"	8.2
NEWJET 60/50	351	93	130	180	174	1"	1"	9

NOCCHI JET

CAST IRON SELF-PRIMING PUMPS

HYDRAULIC PERFORMANCE

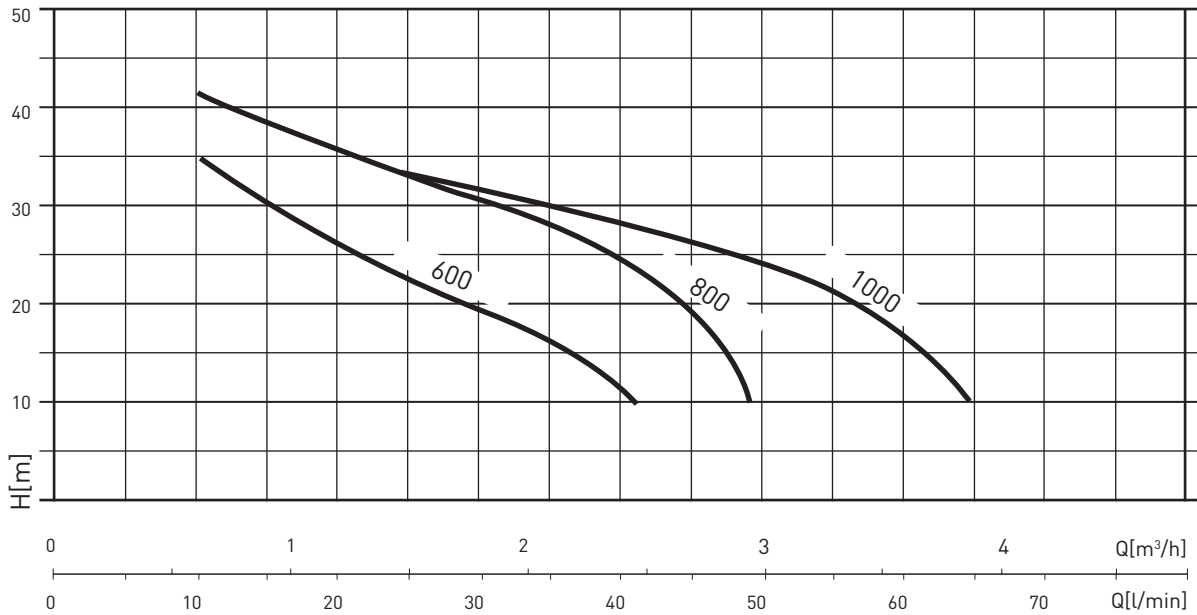

PERFORMANCE TABLE

MODEL	Motor power (P2)		Motor power (P1)		VOLT. (V)	I _n (A)	μF	Q	m.c.a. / m.c.w.						
	HP	kW	HP	kW					l/min	5	20	30	40	50	60
								m³/h	0.3	1.2	1.8	2.4	3	3.6	4.2
JET 600 M JET 600 T	0.8	0.6	0.9	0.7	1 - 230 3 - 230/400	3.2 1.9-1.1	8	m.c.a. / m.c.w.	38	25	20	11			
JET 800 M JET 800 T	1	0.75	1.3	1	1 - 230 3 - 230/400	4.5 3.6-2.1	12.5		44	36	31	27	7		
JET 1000 M JET 1000 T	1.36	1	1.5	1.1	1 - 230 3 - 230/400	5 3.8-2.2	16		45	36	32	28	25	15	3

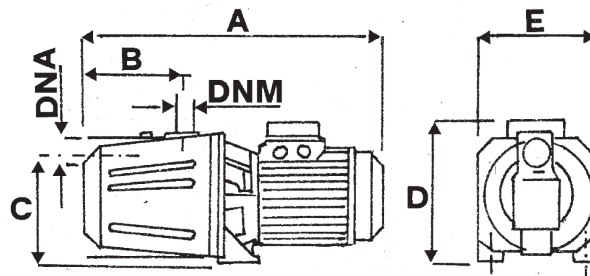

OVERALL DIMENSIONS AND WEIGHTS

MODEL	Dimensions mm.							WEIGHTS (Kg)
	A	B	C	D	E	DNA	DNM	
JET 600	400	147	160	190	182	1"	1"	13.7
JET 800	400	147	160	190	182	1"	1"	14.2
JET 1000	425	147	160	190	182	1"	1"	16.8

NOCCHI JET

CAST IRON SELF-PRIMING PUMPS

HYDRAULIC PERFORMANCE

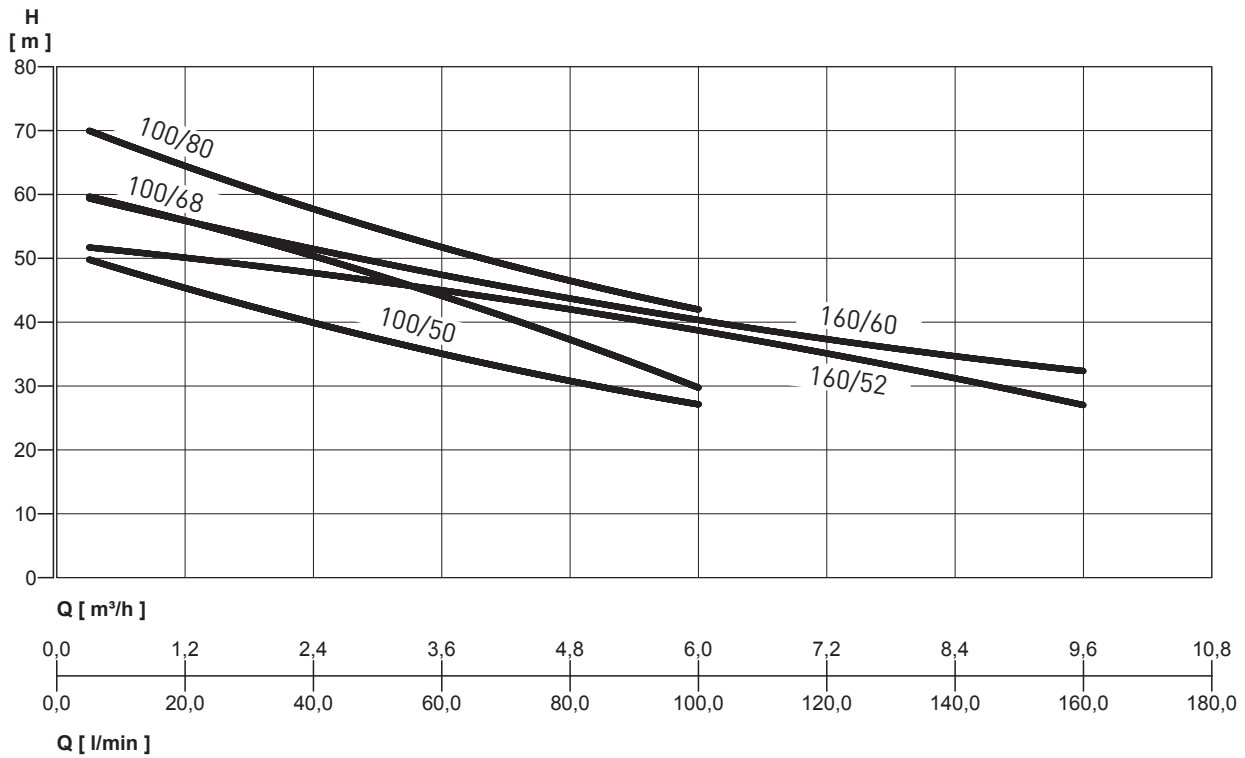

PERFORMANCE TABLE

MODEL	Motor power (P2)		Motor power (P1)		VOLT. (V)	I _n (A)	μF	Q	m.c.a. / m.c.w.								
	HP	kW	HP	kW					l/min	5	20	40	60	80	100	130	160
									m³/h	0.3	1.2	2.4	3.6	4.8	6	7.8	9.6
JET 100/50 M JET 100/50 T	1.5	1.1	2.2 2.4	1.7 1.8	1 ~ 230 3 ~ 230/400	8.1 5.5-3.2	35	m.c.a. / m.c.w.	50	45	40	35	31	27			
JET 100/68 M JET 100/68 T	2	1.5	2.8 2.4	2.1 2.8	1 ~ 230 3 ~ 230/400	9.8 5.5-3.2	40		60	55.5	49	47.5	34.5	30.5			
JET 100/80 T	3	2.2	3.5	2.6	3 ~ 230/400	8.1-4.7			70	64.3	58	51.5	46.5	42			
JET 160/52 M JET 160/52 T	2	1.5	3.1 2.8	2.3 2.1	1 ~ 230 3 ~ 230/400	10.5 6.9-4.0	40		52	49.5	48	45	42	38.7	33.2	27	
JET 160/60 T	3	2.2	3.5	2.6	3 ~ 230/400	8.1-4.7			59	55.6	53	47	43.4	40	36	32.5	

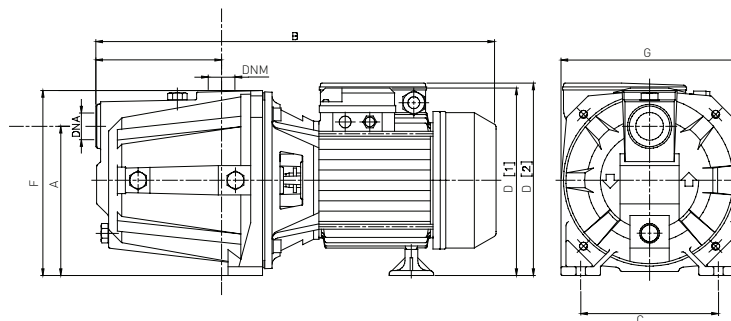

OVERALL DIMENSIONS AND WEIGHTS

MODEL	Dimensions mm.									WEIGHTS (Kg)
	A	B	C	D	E	F	G	DNA	DNM	
JET 100/50	170	508	180	247	220	223	157	1" 1/2	1"	25.5
JET 100/68 - 160/52	170	508	180	247	220	223	157	1" 1/2	1"	26.6
JET 100/80 - 160/60	170	508	180		220	223	157	1" 1/2	1"	28.1