



Data sheet

# Data sheet

## APP 11-13



Nessie®  
Danfoss  
PUMP  
Type: APP 13/1200  
Serial No. 37875601-172  
Code No. 180B3214  
CE

**Table of Contents**

1.	Introduction .....	3
2.	Benefits.....	3
3.	Technical data .....	4
4.	Variants.....	4
5.	Flow at different rpm.....	5
6.	Flushing valve.....	6
7.	Power requirements .....	6
8.	Temperature and corrosion .....	7
8.1	Operation.....	7
8.2	Storage .....	7
9.	Noise level .....	7
10.	Filtration.....	8
11.	Dimensions .....	8
12.	Dimensions, complete unit.....	9
13.	Installation.....	10
13.1	Mounting.....	10
13.2	Open-ended system with direct water supply.....	10
13.3	RO system with APP pump .....	11
14.	Service.....	11
14.1	Warranty.....	11
14.2	Maintenance.....	11
14.3	Repair .....	11

**1. Introduction**

APP 11-13 pumps are designed to supply low viscosity and corrosive fluids under high pressure, eg. in seawater reverse osmosis filtration applications and for high pressure salt water pumping.

The pumps are based on the positive displacement principle (axial piston design) which enables a very light and compact design, and they are designed so that the lubrication of the moving parts in the pumps is provided by the fluid itself. No oil lubrication is thus required.

The pumps are supplied with an integrated flushing valve that allows the salt water to flow from inlet to the outlet, when the pump is not running.

All parts included in the pumps are designed to provide long service life, i.e. long service life with a constantly high efficiency and minimum service required.

The pumps are fixed displacement pumps in which the flow is proportional to the number of revolutions of the input shaft and the pump displacement.

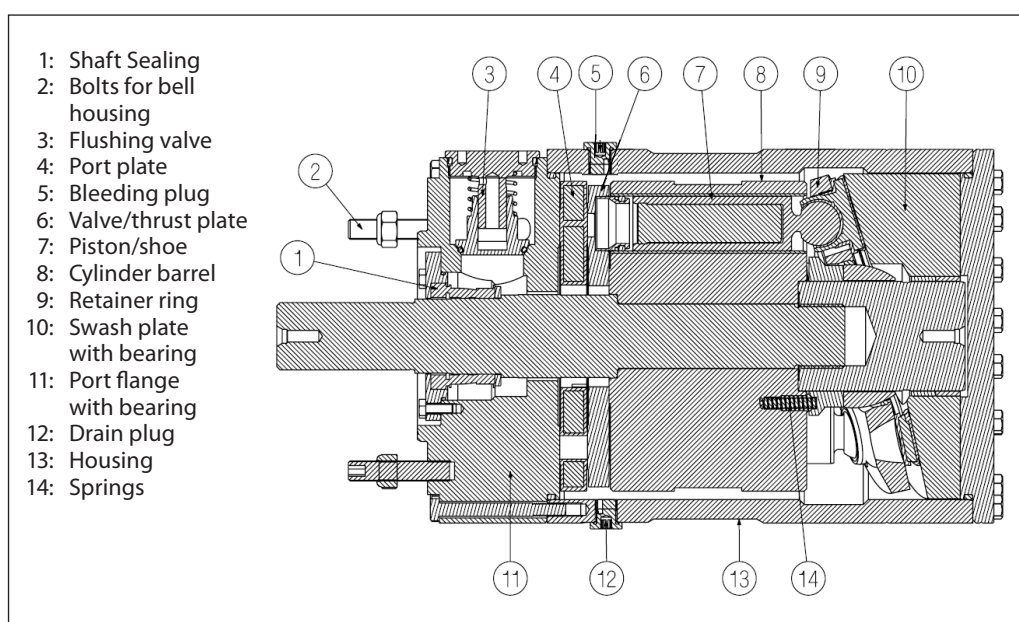

**2. Benefits**

- One of the smallest and lightest pumps on the market.
- Can be powered by a combustion engine provided that a special coupling is used.
- Long service life / no preventive maintenance required in the warranty period.
- Generates insignificant pulsations in the pressure line.
- No oil lubricant required.
- Integrated flushing valve.
- All parts of the pump are made of non-corrosive materials, e.g. Duplex (EN1.4462/UNS S31803-S32205) and Super Duplex (EN1.4410/UNS S32750) stainless steel and carbon reinforced PEEK.
- High efficiency.

3. Technical data

APP Pumps		APP 11 / 1200	APP 11 / 1500	APP 13 / 1200	APP 13 / 1500
Code number		180B3212	180B3211	180B3214	180B3213
Geometric displacement	cm <sup>3</sup> /rpm	166	137	197	166
	in <sup>3</sup> /rpm	10.1	8.4	12.0	10.1
Rated flow at max. speed 1)	m <sup>3</sup> /h	11.0	11.1	13.1	13.5
	gpm	48.4	49	57.7	59.3
Outlet min. pressure 2)	bar	30	30	30	30
	psi	435	435	435	435
Outlet max. pressure, cont. 3)	bar	80	70	80	70
	psi	1160	1015	1160	1015
Inlet min. pressure	bar	2	2	2	2
	psi	29	29	29	29
Inlet max. pressure, cont.	bar	5	5	5	5
	psi	72.5	72.5	72.5	72.5
Inlet max. pressure, peak	bar	10	10	10	10
	psi	145	145	145	145
Max. speed cont.	rpm	1200	1500	1200	1500
Min. speed cont.	rpm	700	700	700	700
Power requirement at max. speed and 60 bar outlet pressure	kW	23	24	27	29
	hp	30.8	32.2	36.2	38.9
Torque at 60 bar outlet pressure	Nm	183	151	217	183
	lbf-ft	135.0	111.4	160.1	135.0
Weight	Kg	75	75	75	75
	lb	165	165	165	165
Integrated flushing valve		YES	YES	YES	YES

- 1) Typical average flow at 60 bar (870 psi)
- 2) For lower pressure, please contact Danfoss RO Sales Organization
- 3) For higher pressure, please contact Danfoss RO Sales Organization

The pumps are designed according to EN809.

4. Variants

- Available as ATEX certified. Category 2, zone 1 and category 3, zone 2.
  - Available with material certificates on wetted parts.
- For more details on the variants, please contact the Danfoss RO Solutions Sales Organisation.

5. Flow at different rpm

When using the diagrams shown below, it is easy to select the pump which fits the application best if the flow required and the rotation speed (rpm) of the pump are known.

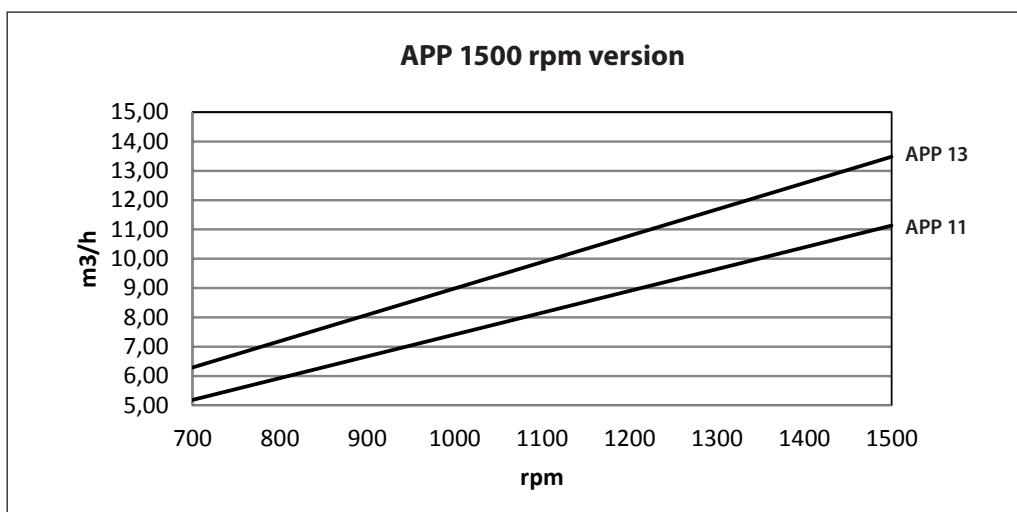
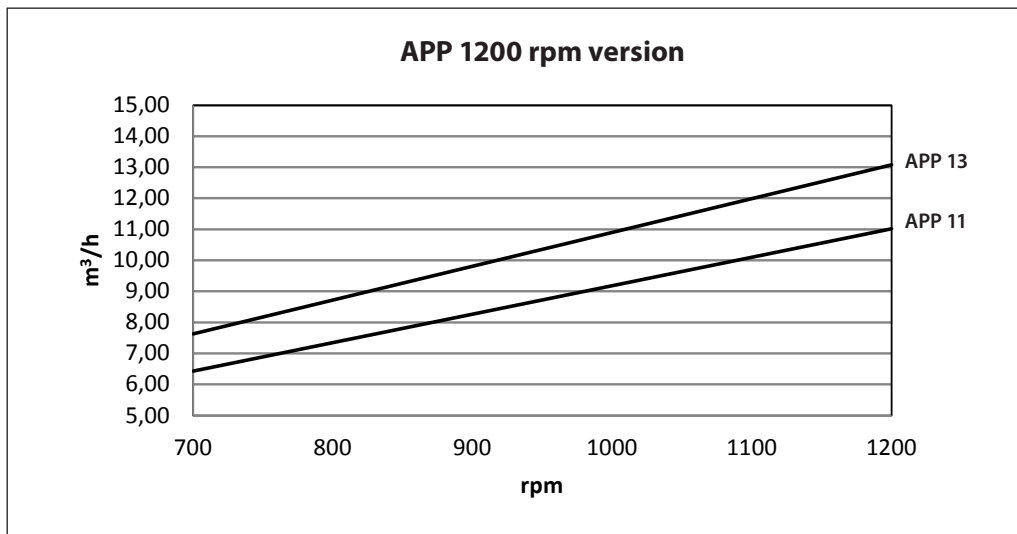

Furthermore, these diagrams shows that the flow can be changed by changing the rotation speed of the pump. The flow/rpm ratio is constant, and the "required" flow can be obtained by changing the rotation speed to a corresponding value. Thus, the required rpm can be determined as:

$$\text{Required rpm} = \frac{\text{Required flow} \times \text{Rated rpm}}{\text{Rated flow}}$$

6. Flushing valve

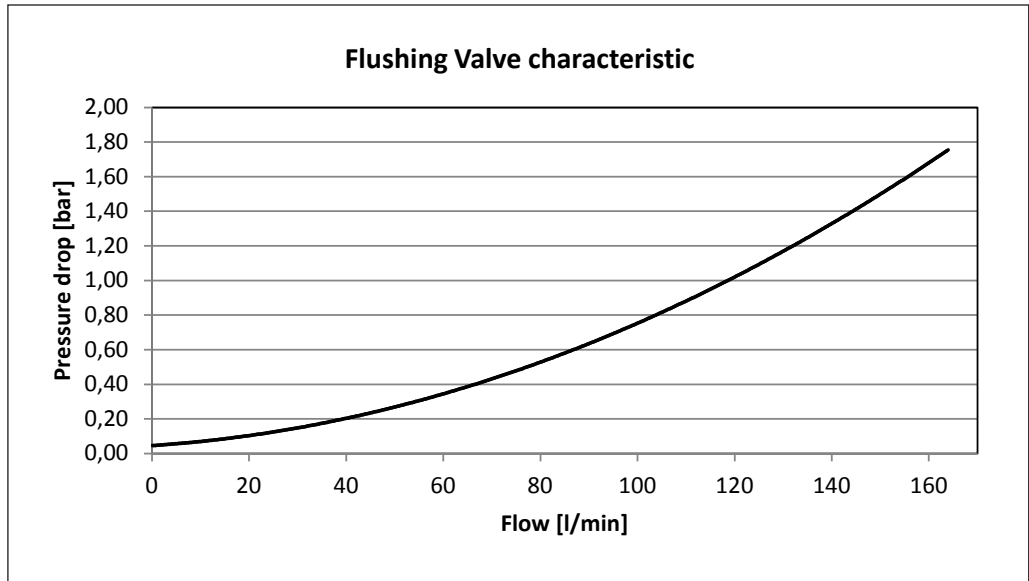

7. Power requirements

Pump model	Flow			Pressure			rpm	Cal. Factor
	l/min	m <sup>3</sup> /h	gpm	60 bar	70 bar	80 bar		
				870 psi	1015 psi	1160 psi		
APP 11 / 1200	184	11,0	48,5	23 kW	27 kW	31 kW	1180	477
APP 11 / 1500	190	11,4	50,1	24 kW	28 kW	32 kW	1480	475
APP 13 / 1200	218	13,1	57,6	27 kW	32 kW	36 kW	1180	482
APP 13 / 1500	230	13,8	60,7	29 kW	34 kW	38 kW	1480	478

The power requirements can be determined using one of the following guiding equations:

$$\text{Required power} = \frac{\text{l/min} \times \text{bar}}{\text{Calc. factor}} \text{ [kW]} \text{ or } \frac{16.7 \times \text{m}^3/\text{h} \times \text{bar}}{\text{Calc. factor}} \text{ [kW]} \text{ or } \frac{0.26 \times \text{gpm} \times \text{psi}}{\text{Calc. factor}} \text{ [kW]}$$

- 1 hp = 0.75 kW
- 1 kW = 1.34 hp
- 1 gpm = 3.79 l/min
- 1 l/min = 0.26 gpm
- 1 m<sup>3</sup>/h = 4.40 gpm
- 1 gpm = 0.23 m<sup>3</sup>/h

**8. Temperature and corrosion**

**8.1 Operation**

Fluid temperature: +2 °C to +50 °C (+35.6 °F to 122 °F) - dependent on the NaCl concentration
Ambient temperature: +2 °C to +50 °C (+35.6 °F to 122 °F)

The chart on the next page illustrates the corrosive resistance of different types of stainless steel related to NaCl concentration and temperature.

All critical parts of the APP water pump is made of Super Duplex.

If the water pump is operated at high salinity, always flush the water pump with fresh water at operation stop in order to minimize the risk of crevice corrosion.

**8.2 Storage**

Storage temperature: -40 °C to +70 °C (-40 °F to 158 °F) – provided that the pump is drained of fluid and stored "plugged".
--

Frost protection is required at temperatures below 2°C. Danfoss recommends using DOWFROST from DOW Chemical Company or Chilsafe mono propylene glycol from Arco Chemical Company.

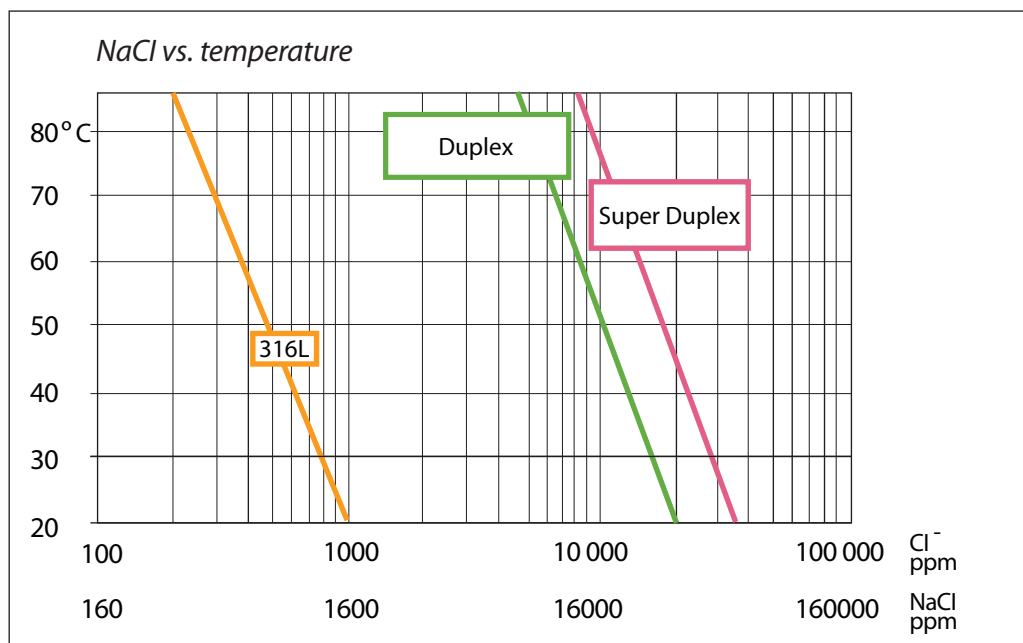

**9. Noise level**

The sound pressure levels,  $L_{PA'} (1m)$  db(A) for APP 11-13 pumps are typically 81 db(A) at 60 bar/1500rpm and 85 db at 80 bar/1500rpm.

Generally, noise will be reduced if speed is reduced and vice versa. Use flexible hoses in order to minimize vibrations and noise.

Since the pump is typically mounted on a bell housing or frame, the noise level must be determined for the complete unit (system).

It is therefore very important that the motor/pump unit is mounted correctly on a frame with antivibration isolation to minimize vibrations and noise.

The noise level is influenced by:

- The speed of the pump, high rpm create more noise than low rpm
- Rigid mounting of the pump generates more noise than flexible mounting
- Pipe mounting direct to the pump increases the noise level compared to a flexible hose
- If using a VFD the motors can produce higher noise values depending on the operation point.

<sup>\*)</sup> 1 meter from the pump unit surfaces (reference box) acc. to EN ISO 20361 section 6.2. Deviation  $\sigma_{TOT} = \pm 1,6 \text{ dB(A)}$

10. Filtration

As water has very low viscosity, the APP pumps have been designed with very narrow clearance in order to control internal leakage rates and improve component performance. Therefore it is important that the inlet water is filtered properly to minimize the wear of the pump.

cartridges typically have only 50% filtration efficiency. This means that for each 100,000 particles reaching the filter, 50,000 particles pass through it compared to only 20 particles in a filter with an efficiency of 99.98%.

The main filter must have a filtration efficiency of 99.98% at 10 µm. We recommend to use precision depth filter cartridges rated 10µm abs. β10>5000 (equivalent to a filtration efficiency of 99.98%). Bag filters and string wound filter

For more information on the importance of proper filtration, please consult our publication "Filtration" (code number 521B1009), which also will provide you with an explanation of filtration definitions and a guidance on how to select the right filter.

11. Dimensions

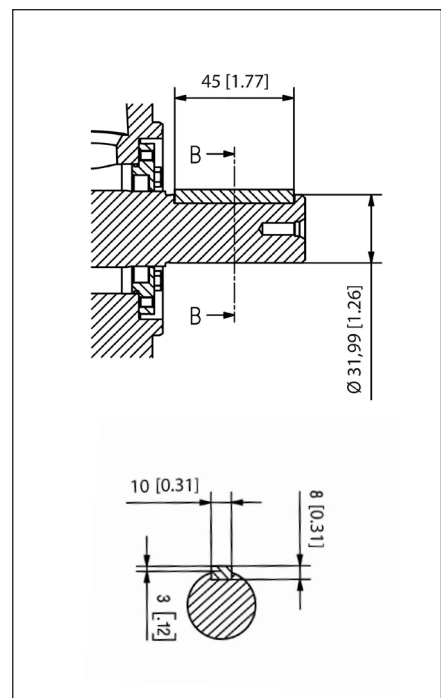
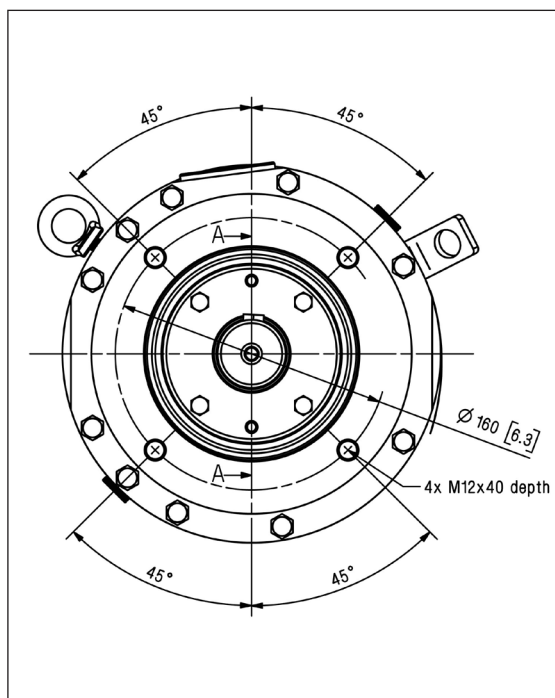
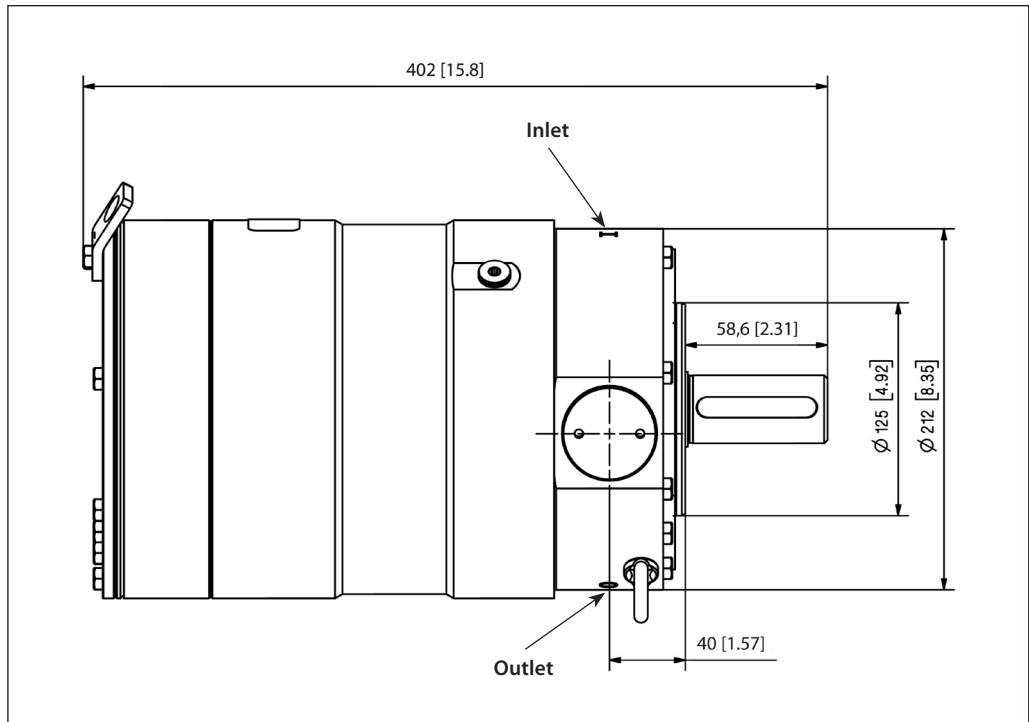



Description		APP11 - APP13
Parallel key, DIN 6885	mm	10 × 8 × 45
	inch	0.39 × 0.31 × 1.77
Bleeding	G ¼", Hexagon AF = 6 mm	
Inlet port	M42 x 1.5; depth 17 mm	
Outlet port	M42 x 1.5; depth 17 mm	
Pump mounting flange	125 B 4	

Accessories	Type	Code no.
2" inlet hose kit 2 m / 79"	2" Victaulic	180Z0298
2" inlet Vic. Super Duplex	2" Victaulic	180Z0166
Non-return valve (outlet) Super Duplex	1,5" Victaulic (OD 48,3 mm)	180H0053

For more details on the accessories, please contact the Danfoss RO Solutions Sales Organisation.

12. Dimensions, complete unit

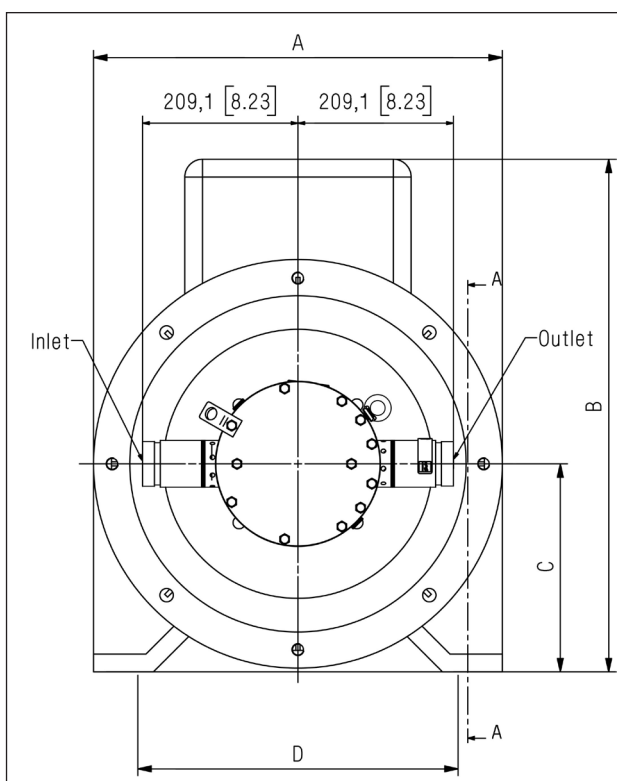
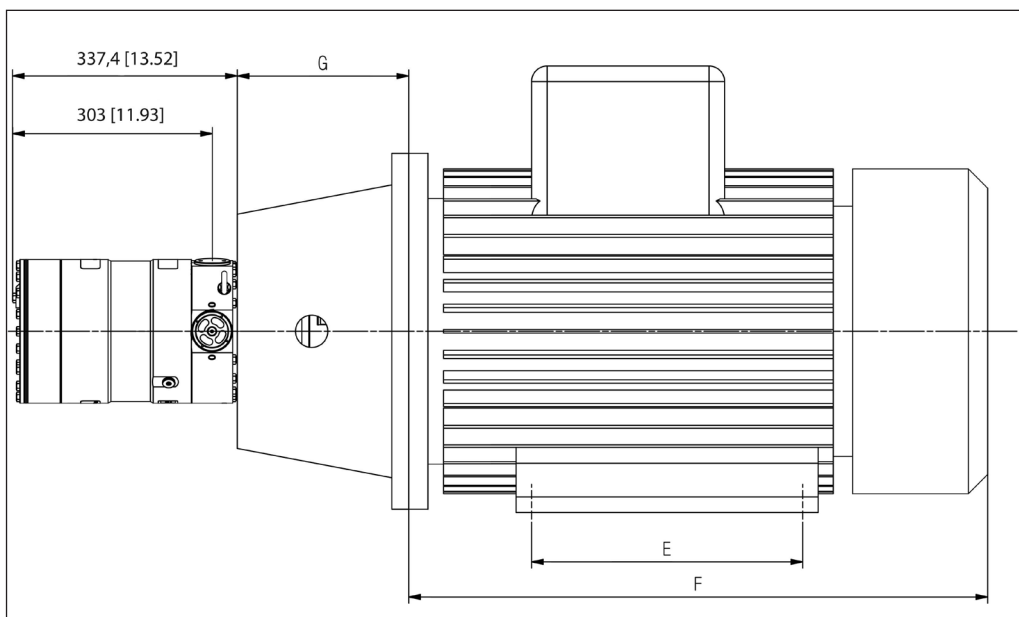

Pump	A (mm)	B (mm)	C (mm)	D (mm)	E (mm)	F (mm)	G (mm)	IEC Electric motor
APP 11	400	513	200	318	305	659	228	30 kW, IEC 200L-4
APP 11	450	561	225	356	311	692	262	30 kW, IEC 225M-6
APP 13	450	561	225	356	286	667	262	37 kW, IEC 225S-4

**Note:** Examples of different pump/motor sizes and drawing dimensions are only for IEC

**motors and couplings. Please always check required motor power and dimensions.**

**13. Installation**

**13.1 Mounting**

The figure below illustrates how to mount the pump and connect it to the electric motor/ combustion engine.

To ensure easy mounting of the flexible coupling without using tools, the tolerances must be dimensioned accordingly.

If alternative mounting is required, please contact Danfoss RO Sales Organization for further information.

**Note:** Any axial and radial loads on the pump shaft must be avoided.

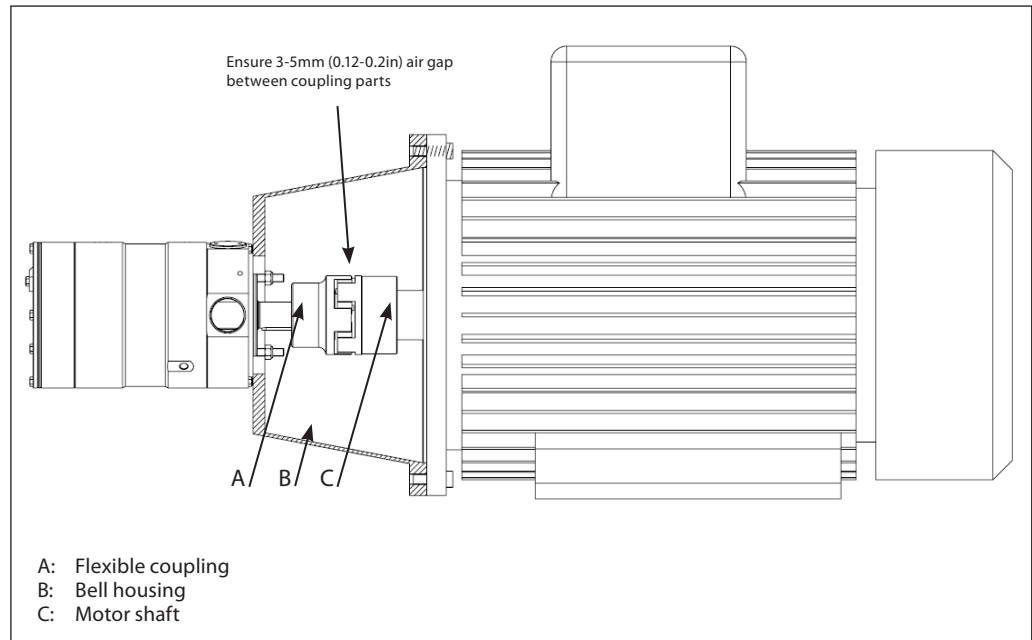

**13.2 Open-ended system with direct water supply**

In order to eliminate the risk of cavitation, a positive inlet pressure is always to be maintained. Please see technical data (section 3) for specific pressure values.

1. Place the filter (1) in the water supply line in front of the pump.
2. Place a monitoring pressure switch (2) - set at min. inlet pressure - between filter and pump inlet. The monitoring switch must stop the pump at pressures lower than min. inlet pressure. Please see technical data (section 3) for specific pressure values.
3. Install a low pressure safety valve or a pressure relief valve (3) in order to avoid system or pump damage in case the pump stops momentarily or is spinning backwards.

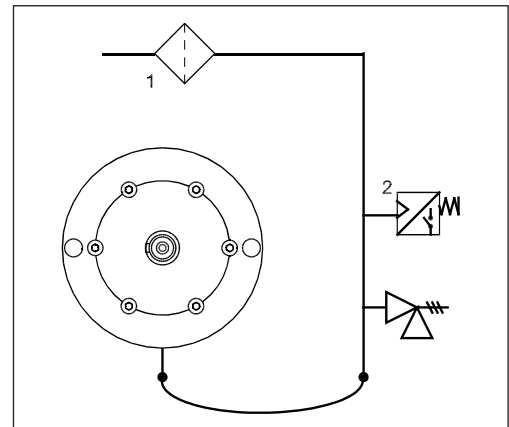

**Note:** If a non-return valve is mounted in the inlet line, a low pressure relief valve is also required between non return valve and pump as protection against high pressure peaks.

**13.3 RO system with APP pump**

1. Dimension the inlet line to obtain minimum pressure loss (large flow, minimum pipe length, minimum number of bends/connections, and fittings with small pressure losses).
2. Place an inlet filter (1) in front of the APP pump (2). Please consult section 10, "Filtration" for guidance on how to select the right filter. Thoroughly clean pipes and flush system prior to start-up.
3. Place a monitoring pressure switch (3) set at min. inlet pressure between filter and pump inlet. The monitoring switch must stop the pump at pressures lower than minimum pressure.
4. Use flexible hoses (4) to minimize vibrations and noise.
5. In order to eliminate the risk of damage and cavitation, a positive pressure at the inlet (5) is always to be maintained at min. inlet pressure and max. inlet pressure. Recommend to install safety valve or a pressure relief valve (9) in order to avoid high pressure peaks in case the pump stops momentarily or is spinning backwards.
6. For easy system bleeding and flushing, a bypass non-return valve (6) is integrated in the APP pump.
7. A non-return valve (7) in outlet can be installed in order to avoid backspin of the pump. The volume of water in the membrane vessel works as an accumulator and will send flow backwards in case of the pump stops momentarily.
8. A safety valve or a pressure relief valve (8) can be installed in order to avoid system damage as the Danfoss APP pump creates pressure and flow immediately after start-up, regardless of any counter-pressure.

**Note: If a non-return valve is mounted in the inlet line, a low pressure relief valve is also required between non return valve and pump as protection against high pressure peaks.**

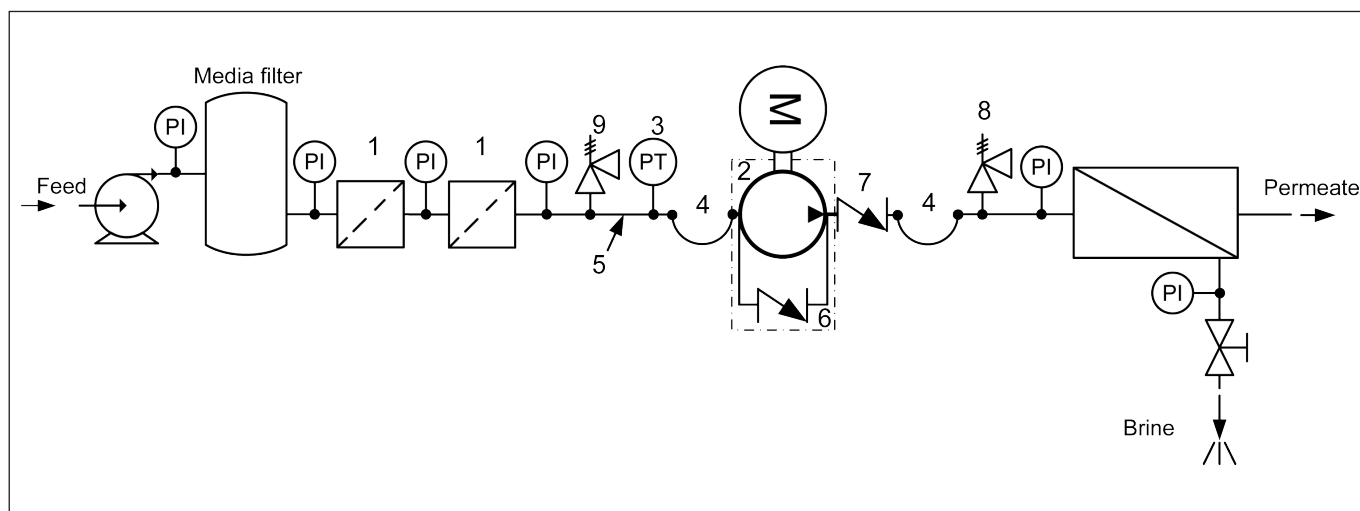

**14. Service**

**14.1 Warranty**

Danfoss APP pumps are designed for long operation, low maintenance and reduced lifecycle costs.

Provided that the pump has been running according to the Danfoss specifications, Danfoss guarantees 8,000 hours service-free operation, however, max. 18 months from date of production.

If Danfoss recommendations concerning system-design are not followed, it will strongly influence the life of the APP pumps.

**14.2 Maintenance**

After 8,000 hours of operation it is strongly recommended to inspect the pump and change any worn parts, e.g. pistons and shaft seal. This is done in order to prevent a potential

breakdown of the pump. If the parts are not replaced, more frequent inspection is recommended according to our guidelines.

**Pump shutdown:**

The APP pumps are made of Duplex/Super Duplex materials with excellent corrosion properties. It is, however, always recommended to flush the pump with freshwater when the system is shut down.

**14.3 Repair**

In case of irregular function of the APP, please contact the Danfoss RO Solutions Sales Organisation.

**Danfoss A/S**  
High Pressure Pumps  
DK-6430 Nordborg  
Denmark

---

Danfoss can accept no responsibility for possible errors in catalogues, brochures and other printed material. Danfoss reserves the right to alter its products without notice. This also applies to products already on order provided that such alterations can be made without subsequential changes being necessary in specifications already agreed. All trademarks in this material are property of the respective companies. Danfoss and the Danfoss logotype are trademarks of Danfoss A/S. All rights reserved.

---